



LC Water Level Monitor Maintenance

Date Originated: 00/00/00 **Revision:** B **Revision Date:** 03/08/04 **Standards No.** 75000002

Subject: For Cleaning of Hard Water Deposits on LC Probe Electrodes

Step 1

Remove retaining screw on cover using a Philips head screw driver.

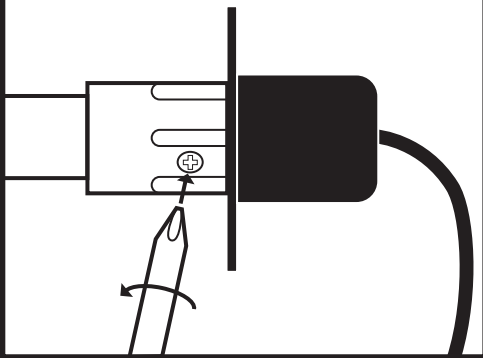

Step 2

Grasp black cap firmly and unscrew the probe cover.

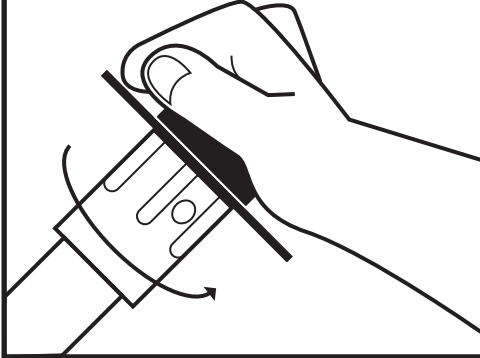

Step 1

Carefully remove electrode assembly.

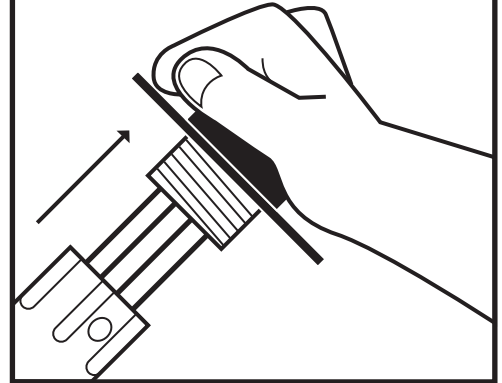

Step 4

Spacers should be located approx. 1/2" above insulation on each probe. Adjust spacers if needed.

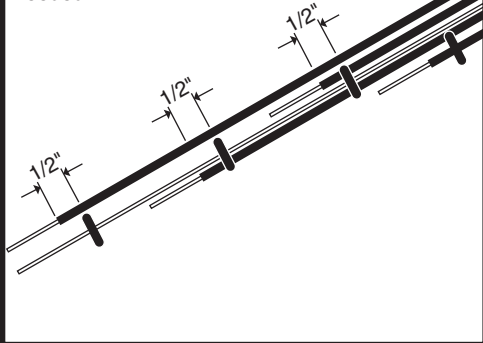

Step 5

Clean each electrode with steel wool to remove deposits.

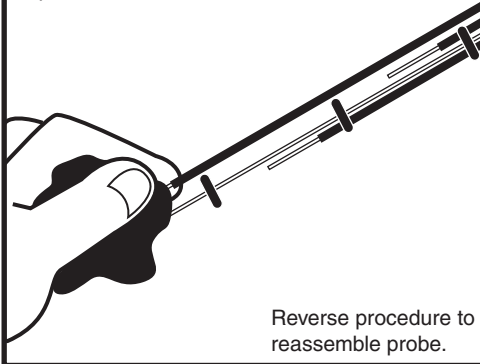

Reverse procedure to reassemble probe.